

SEALING

- SEMI OR FULLY AUTOMATIC
- UNIFORM OR RANDOM CASE SIZES
- TOP AND BOTTOM SEALING
- SIDE OR VERTICAL SEALING
- ACCESSORIES



Case sealing

Case sealers for uniform case sizes

T-100 Mini Mini
For the very small cartons - Top and bottom closure
Essential part of the packing station in many industries e.g. pharmaceutical, food, electrical components, toiletries.

Page 1



T-100 motorized hand dispenser - Top and bottom closure

Page 2



T-10 for round-the-clock applications - Top- and bottom closure
Very sturdy machine for high requirements.

Page 3



T-400 Case sealer with automatic flap closure - Top and bottom closure
The machine is constructed for "round-the-clock" operation with minimum service requirements.

Page 5

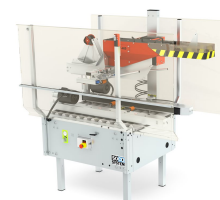

ST-10 For side taping- Top- or bottom closure

Page 7



TT-10 For flat items - Top closure
TT-10 is designed to handle primarily flat items such as graphics, mirrors, cabinet doors, half-knock-down furniture, book parcels, etc. requiring top taping only.

Page 9



T-2000 top and bottom sealing
The machine can be adjusted from both sides.

Page 11



T-2002 with top and bottom drive - top and bottom sealing

Page 13



T-4000/-4200 with automatic flap folding - top and bottom sealing Page 15



HM-4200 With automatic flap folding – top sealing with hotmelt Page 17

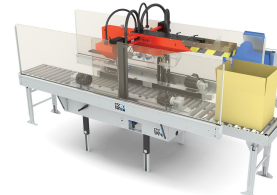

Case sealers for random case sizes

T-55 Automatic adjustment for case size - Top and bottom closure Page 18
The automatic height and width adjustment makes the T-55 ideal in packing lines where case sizes vary, e.g. in the dispatch department of warehouses. Two operators can work simultaneously on either side of the packing table.



T-602 Fully automatic - Top and bottom closure Page 21

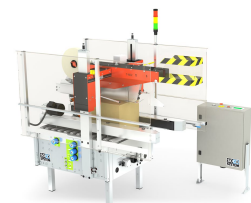

T-55 Bottom closure - Automatic adjustment for case size Page 22



Flap closers for uniform case sizes

FT-10/-12 Manual height and width adjustment. Page 23



Flap closers for random case sizes

FT-55 Automatic height and width adjustment. Page 24



Accessories

Tape dispensers - Standard For case sealers operated from the right. Page 25



Tape dispensers - Opposite hands
For case sealers operated from the left.

Page 26



Spare parts kit for dispensers
The tape dispenser is the heart of a case sealer.

Page 27



Tape alarm
All dispensers can be fitted with a monitoring system to supervise the sealing process.

Page 27

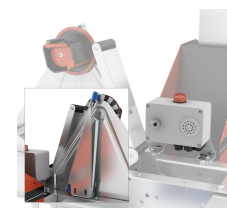

3-flap folder for T-10 and T-100

Page 28



Easy-open Zipper system
A small piece of paper with a big effect.

Page 28

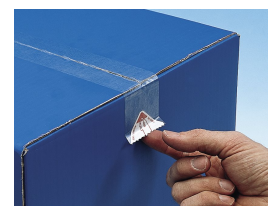

Side pressure guide for T-55 and T-602

Page 29



Top drive

Page 29

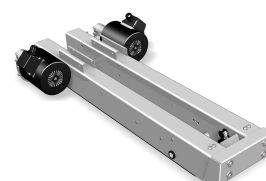

Safety switch

Page 30

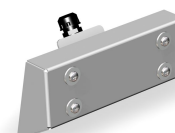

Narrow side-drives

Page 30

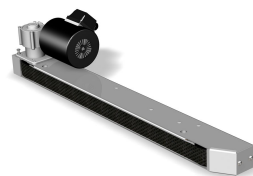

Wide side-drives

Page 30

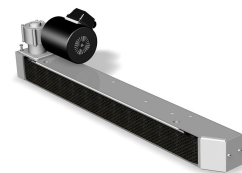

Extended side-drives

Page 31



Raised side-drives

Page 31



Safety cover

Page 32

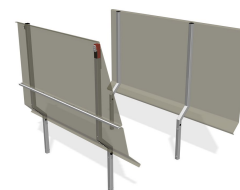

Fixed pillar stop

Page 32

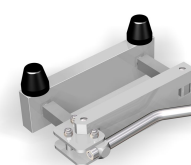

Resilient stop

Page 32

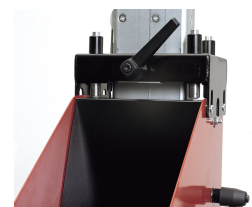

Solutions

Inline system

Offers an efficient and ergonomically correct working station on few square metres when combined with SOCO SYSTEM case sealers.

Page 33



Boomerang system

The boomerang system is ideal as a "one-man packing station" where a single operator can fill, seal, and palletise cases from practically the same position.

Page 34



Case sealers for uniform case sizes

T-100 Mini MiniFor the very small cartons - Top and bottom closure

Essential part of the packing station in many industries e.g. pharmaceutical, food, electrical components, toiletries.

The T-100 Mini Mini is the ideal case sealer for small cases. The machine is designed to assure a safe and gentle tape closure of small cases, without any risk of jammed fingers.

- Easy to adjust for different case sizes
- Easy tape and dispenser replacement
- Very compact design
- Easy to maintain with low maintenance and sparepart costs
- Wide range of accessory equipment, e.g. braked castors, infeed and outfeed conveyors
- Electro-zink finish



Item no.

Model	Item no.
T-100 Mini Mini 3-5-9	460138353

All measurements are in mm. Subject to alteration.

Specifications	T-100 Mini Mini 3-5-9
Case dimensions*	
Max. (LxWxH) mm	∞ x 350 x 500
Min. (LxWxH) mm	60 x 60 x 100
50 mm	●
25 - 30 mm	●
Height 50 mm	●
995 - 650 mm	●
Weight kg	120
Capacity*	Max. 30/ min.
Electric specifications	3 x 230/400 V, 50-60 Hz, or 3 x 415/460 V, 50-60 Hz. Connected load 0.3 kW. Other specifications available upon request.
Tape diameter	Max. 360 mm.

● Standard ○ OptionalNB! Tall cases with a small footprint will be subject to test. Also smaller cases can be sealed, again subject to test.* Depending on the quality, construction and size of the box.All Measurements are in mm. Right to alter specifications reserved.

Case sealers for uniform case sizes

T-100 motorized hand dispenser - Top and bottom closure

The features of the T-100 series are compact construction, low price, small shipping cases, and simple handling in retail distribution.

All vital parts, such as dispensers, belt drives and top assembly, boast the well known SOCO SYSTEM top quality.

Basic Models

T-100 Mini and T-100. (see table)

The T-100 is available with an electro-zinc or a stainless steel finish. In the stainless steel version, all external parts, excl. gears, motors, and aluminium parts, are made of stainless steel. The machine is easy to clean and resistant to damp and moisture.

- Easy to adjust for different case sizes.
- Easy tape and dispenser replacement.
- Easy to maintain with low maintenance and spare parts costs.

Electro-galvanised steel.



Item no.	
Model	Item no.
T-100 Mini 3-5-9	460148323
T-100 5-5-9	440148323

All measurements are in mm. Subject to alteration.

Specifications	T-100 Mini 3-5-9	T-100 5-5-9
Case dimensions*		
Max. (LxWxH) mm	∞ x 350 x 505	∞ x 520 x 505
Min. (LxWxH) mm	160 x 105 x 110	160 x 90 x 90/130**
Tape overlap		
70 mm	○	○
50 mm	●	●
Tape width		
25 - 30 mm	○	○
38 - 50 mm	●	●
Height 50 mm	●	●
Working height max./min.		
950 - 635 mm	●	●
700 - 510 mm	○	○
Weight kg	140	150
Capacity*	Max. 30/ min.	
Electric specifications	3 x 230/400 V, 50-60 Hz. or 3 x 415/460 V, 50-60 Hz. Connected load 0.3 kW. Other specifications available upon request.	
Tape diameter	T-100 Mini: max. 360 mm. T-100: max. 370 mm.	

● Standard ○ Optional* Depending on the construction and quality of the case. ** Without or with side pressure rollers. All measurements are in mm. Subject to alteration.

Accessories

- ▶ Inline system
- ▶ Boomerang system
- ▶ Tape dispensers - Standard
- ▶ Spare parts kit for dispensers
- ▶ 3-flap folder for T-10 and T-100
- ▶ Braked castors

Case sealers for uniform case sizes

T-10 for round-the-clock applications - Top and bottom closure

Very sturdy machine for high requirements.

Also available in stainless steel, e.g. for the food industry where machines are required that are easy to clean and maintain in order to meet the increasing demand for hygiene.

Basic models

T-10 and T-10 Maxi (see table). Both models are available with extra high pillars. T-10 Maxi is especially suitable in industries where large cases are handled. In its standard version, the T-10 Maxi is fitted with a 75 mm dispenser with 70 mm tape overlap.

- Easy to adjust for different case sizes.
- Easy tape and dispenser replacement.
- Strong and compact design.
- Easy to maintain with low maintenance and spare parts costs.
- Electro-galvanised or stainless steel finish.



Item no.	
Model	Item no.
T-10 5-5-7	435646713
T-10 5-8-7	435646913
T-10 Maxi 7-5-7	435642133
T-10 Maxi 7-8-7	435642333

All measurements are in mm. Subject to alteration.

Specifications	T-10 5-5-7	T-10 5-8-7	T-10 Maxi 7-5-7	T-10 Maxi 7-8-7
Case dimensions*				
Max. (LxWxH) mm	∞ x 515 x 505	∞ x 515 x 815	∞ x 725 x 505	∞ x 725 x 815
Min. (LxWxH) mm	140 x 90 x 80/120**	140 x 90 x 80/120**	140 x 140 x 110/150**	155 x 140 x 110/150**
Tape overlap				
70 mm	●	●	●	●
50 mm	○	○	○	○
Tape width				
25 - 30 mm	○	○	○	○
38 - 50 mm	●	●	○	○
50 - 75 mm	○	○	●	●
Side drives				
Height 50 mm	●	●	○	○
Height 80 mm	○	○	●	●
Working height max./min.				
920 - 820 mm	○	○	○	○
820 - 720 mm	○	○	○	○
720 - 620 mm	●	●	●	●
620 - 520 mm	○	○	○	○
520 - 420 mm	○	○	○	○
Weight kg	165	165	170	170
Capacity*	Max. 30/ min.			
Electric specifications	3 x 230/400 V, 50-60 Hz, or 3 x 415/460 V, 50-60 Hz. Connected load 0.3 kW. Other specifications available upon request.			
Tape diameter	Max. 385 mm.			

● Standard ○ Optional * Depending on the construction and quality of the case. ** Without or with side pressure rollers. Subject to alteration.

Case sealers for uniform case sizes

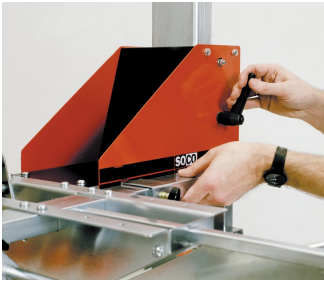

Easy and quick height adjustment.

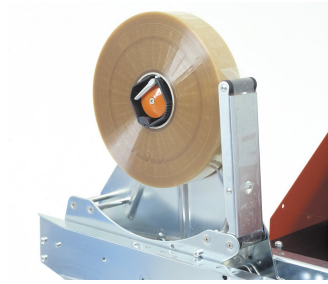

High quality tape dispensers.



Efficient side drives easy to adjust to relevant case size.

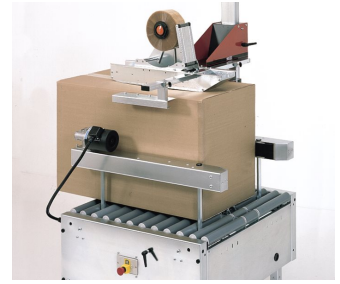

Raised side drives for high cases.



T-10 with stamp coder Various coding equipment is available for the T-10 series: side, top and bottom coders. (Kirk Food A/S)

Accessories

- ▶ 3-flap folder for T-10 and T-100
- ▶ Tape dispensers - Standard
- ▶ Spare parts kit for dispensers
- ▶ Braked castors

Machine dimensions

T-10 5-5-7 / 5-8-7

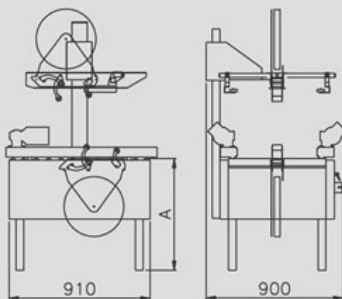

T-10 Maxi 7-5-7 / 7-8-7

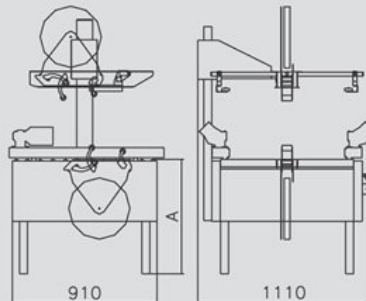

Alle measures are in mm. A = working height. Subject to alteration.

Case sealers for uniform case sizes

T-400 Case sealer with automatic flap closure - Top and bottom closure

The machine is constructed for "round-the-clock" operation with minimum service requirements.

The short length of the machine ensures high production capacity and maximum space utilisation. Ideal for integration into fully automatic packaging lines of uniform cases in batches.

Basic Models

The standard version is available in three constructions (see table). All three machines can be fitted with extra-high pillars.

- Easy to adjust for different case sizes.
- Easy tape and dispenser replacement.
- Compact design.
- Combined with feed-in control function, efficient separation and maximum utilisation of the capacity of the case sealer is ensured.
- Easy to maintain with low maintenance and spare parts costs.

Electro-galvanised or stainless steel finish.



Item no.

Model	Item no.
T-400 5-5-7	441726713
T-400 5-8-7	441726913
T-402 5-5-7	441736713
T-402 5-8-7	441736913
T-402 Maxi 7-8-7	441732333

All measurements are in mm. Subject to alteration.

Case sealers for uniform case sizes

Specifications	T-400 5-5-7	T-400 5-8-7	T-402 5-5-7	T-402 5-8-7	T-402 Maxi 7-8-7
Case dimensions*					
Max. (LxWxH) mm	550 x 460 x 470	550 x 460 x 770	750 x 460 x 470	750 x 460 x 770	750 x 710 x 625
Min. (LxWxH) mm	200 x 120 x 95	200 x 120 x 95	200 x 120 x 95	200 x 120 x 95	200 x 170 x 125
Tape overlap					
70 mm	●	●	●	●	●
50 mm	○	○	○	○	○
Tape width					
25 - 30 mm	○	○	○	○	○
38 - 50 mm	●	●	●	●	○
50 - 75 mm	○	○	○	○	●
Side drives					
Height 50 mm	●	●	●	●	○
Height 80 mm	○	○	○	○	●
Working height max./min.					
920 - 820 mm	○	○	○	○	○
820 - 720 mm	○	○	○	○	○
720 - 620 mm	●	●	●	●	●
620 - 520 mm	○	○	○	○	○
520 - 420 mm	○	○	○	○	○
Weight kg	175	175	175	175	220
Capacity*	Max. 18/min.				
Electric specifications	3 x 230/400 V, 50-60 Hz, or 3 x 415/460 V, 50-60 Hz. Connected load 0.3 kW. Other specifications available upon request.				
Air consumption	Max. 0.6 l at 6 bar per case.				
Tape diameter	Max. 385 mm.				
● Standard ○ Optional* Depending on the construction and quality of the case. Subject to alteration.					



T-402 in action

Case sealer with controller belt at the inlet end. Other conveyor modules take care of transportation to and from the machine.

Accessories

- ▶ Tape dispensers - Standard
- ▶ Spare parts kit for dispensers
- ▶ Tape alarm
- ▶ Easy-open Zipper system

Case sealers for uniform case sizes

ST-10 For side taping- Top- or bottom closure

Side sealer specially designed for packing stations where the cases are filled from the end and sealed lying down. The ST-10 is also suitable for operation in automatic packing lines with case packers.

Basic models

ST-10 and ST-10 Maxi (see table).

Special purpose machine

The ST-10 is designed for a multitude of special applications. The standard machine can be easily modified to seal cases which differ in size from the standard.

- Easy to adjust for different case sizes.
- Easy tape and dispenser replacement.
- Fitted with top and bottom drive belts.
- Electro-galvanised finish.



Item no.	
Model	Item no.
ST-10 5-5-7	439396713
ST-10 Maxi 7-5-7	439397113
All measurements are in mm. Subject to alteration.	

Specifications	ST-10 5-5-7	ST-10 Maxi 7-5-7
Case dimensions*		
Max. (LxWxH) mm	∞ x 530 x 200	∞ x 740 x 200
Min. (LxWxH) mm	140 x 125 x 50	140 x 200 x 50
Tape overlap		
70 mm	●	●
50 mm	○	○
Tape width		
38 - 50 mm	●	●
50 - 75 mm	○	○
Working height max./min.		
920 - 820 mm	○	○
820 - 720 mm	○	○
720 - 620 mm	●	●
620 - 520 mm	○	○
520 - 420 mm	○	○
Weight kg	165	170
Capacity*	Max. 30/ min.	
Electric specifications	3 x 230/400 V, 50-60 Hz, or 3 x 415/460 V, 50-60 Hz. Connected load 0.3 kW. Other specifications available upon request.	
Tape diameter	Max. 385 mm.	

● Standard ○ Optional* Depending on the construction and quality of the case. Subject to alteration.

Case sealers for uniform case sizes

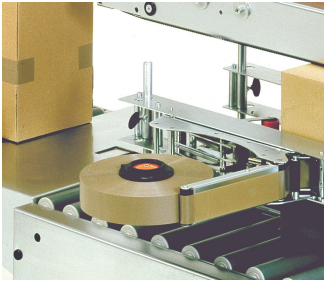

High quality tape dispensers

The tape dispenser for the ST-10 are standard SOCO SYSTEM dispensers modified by means of an adapter system. The quick-lock system makes it easy to replace the dispensers.

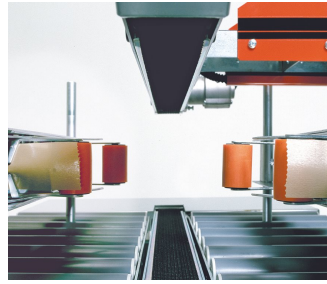

Efficient drive belts The ST-10 is fitted with drive belts at top and bottom.

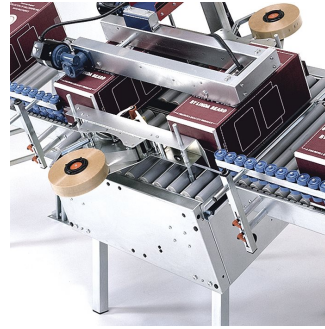

Tilted legs for an efficient solution.

Accessories

- ▶ Tape dispensers - Standard
- ▶ Spare parts kit for dispensers
- ▶ Braked castors

Case sealers for uniform case sizes

TT-10 For flat items - Top closure

TT-10 is designed to handle primarily flat items such as graphics, mirrors, cabinet doors, half-knock-down furniture, book parcels, etc. requiring top taping only.

Basic models

TT-10 and TT-10 Maxi (see table).

TT-10 Top and bottom sealer

The brush unit can be removed without the use of tools and replaced by a standard dispenser. In this way, the TT-10 can be used as a top and bottom sealer for traditional cases.

- Easy to adjust for different case sizes.
- Easy tape and dispenser replacement.
- Easy to maintain with low maintenance and spare parts costs.

Electro-galvanised finish.



Item no.	
Model	Item no.
TT-10 5-5-7	439386723
TT-10 Maxi 7-5-7	439387123

All measurements are in mm. Subject to alteration

Specifications	TT-10 5-5-7	TT-10 Maxi 7-5-7
Case dimensions*		
Max. (LxWxH) mm	∞ x 670 x 200	∞ x 880 x 200
Min. (LxWxH) mm	140 x 150 x 10	140 x 200 x 10
Tape overlap		
70 mm	○	○
50 mm	●	●
Tape width		
25 - 30 mm	○	○
38 - 50 mm	●	●
Working height max./min.		
920 - 820 mm	○	○
820 - 720 mm	○	○
720 - 620 mm	●	●
620 - 520 mm	○	○
520 - 420 mm	○	○
Weight kg	165	170
Capacity*	Max. 30 cases/ min.	
Electric specifications	3 x 230/400 V, 50-60 Hz or 3 x 415/460 V, 50-60 Hz. Connected load 0.3 kW. Other specifications available upon request.	
Air consumption	Max. 0.3 l at 6 bar per case.	
Tape diameter	Max. 385 mm.	

● Standard ○ Optional* Depending on the construction and quality of the case. Subject to alteration.

Case sealers for uniform case sizes

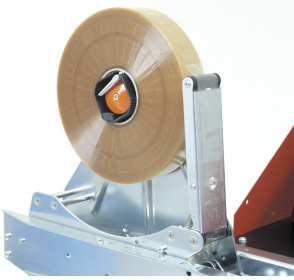

Top dispenser Modified dispenser from SOCO SYSTEM's complete programme. Available for tape widths of 38-50 mm.

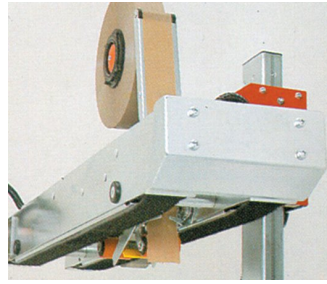

Double drive belts Double drive belts at top also provide an effective system for comparatively heavy products handled in the paper and furniture industries. As an extra precaution, the top drive is fitted with an inlet security to stop the machine in case of fingers becoming trapped between the case and the top drive.



Efficient brush system SOCO SYSTEM's unique brush system in the roller table ensures that the tape overlap is brushed down onto the underside of the case.

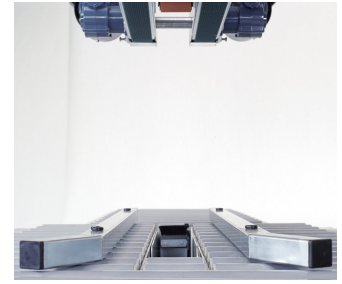

Sideguides The compact side guide arrangement makes it possible to seal cases which are only a few millimetres high. At the same time, it is designed to handle very heavy cases.

Accessories

- ▶ Tape dispensers - Standard
- ▶ Spare parts kit for dispensers
- ▶ Braked castors

Case sealers for uniform case sizes

T-2000 top and bottom sealing

The machine can be adjusted from both sides.

The machine is easy to clean and resistant to vapour and moisture.

Basic models

The compact machine is available in two basic models T-2000 and T-2000 Maxi. T-2000 Maxi is suited for use in industries handling large cases.

- The machine is very easy to adjust for current case size and adjustment can be carried out from both sides.
- Easy change of tape.
- Compact design.
- Easy and economical maintenance.
- Extensive accessory programme, e.g. braked castors, packaging tables, and conveyors.



Item no.	
Model	Item no.
T-2000 5-5-9	482208313
T-2000 5-8-9	482208513
T-2000 Maxi 7-5-9	482203773
T-2000 Maxi 7-8-9	482203973

All measurements are in mm. Subject to alteration.

Specifications	T-2000 5-5-9	T-2000 5-8-9	T-2000 Maxi 7-5-9	T-2000 Maxi 7-8-9	test
Case dimensions*					
Max. (LxWxH) mm	∞ x 520 x 520	∞ x 515 x 820	∞ x 720 x 520	∞ x 720 x 820	
Min. (LxWxH) mm	140 x 90 x 90	140 x 90 x 90	140 x 130 x 100	155 x 130 x 100	
Tape overlap					
70 mm	●	●	●	●	
50 mm	○	○	○	○	
Tape width					
25 - 30 mm	○	○	○	○	
38 - 50 mm	●	●	○	○	
50 - 75 mm	○	○	●	●	
Side drives					
Height 50 mm	●	●	○	○	
Height 80 mm	○	○	●	●	
Weight kg	150	155	160	165	
Capacity*	Max. 30/ min.				
Electric specifications	3 x 230/400 V, 50-60 Hz, or 3 x 415/460 V, 50-60 Hz. Connected load 0.3 kW. Other specifications available upon request.				
Tape diameter	Max. 385 mm.				
● Standard ○ Optional* Depending on the construction and quality of the case. Subject to alteration.					

Case sealers for uniform case sizes

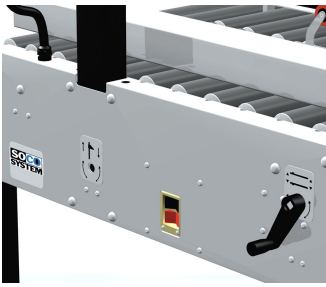

Crank handle adjustment for case size. The machine can be adjusted from both sides.

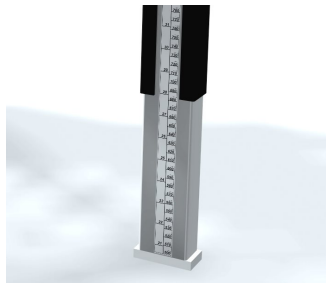

Tape measure on the legs of the machine for easy and precise working height adjustment.



Side pressure guides and centrally placed emergency stop.

Accessories

- ▶ Tape dispensers - Standard
- ▶ Spare parts kit for dispensers
- ▶ Braked castors

Case sealers for uniform case sizes

T-2002 with top and bottom drive - top and bottom sealing

The driven top and bottom drives make the machine especially suitable for overfilled cases and high, narrow, or short cases.

The machine is easy to clean and resistant to vapour and moisture.

Basic models

The compact machine is available in two basic models T-2002 and T-2002 Maxi.

- The machine is very easy to adjust for current case size and adjustment can be carried out from both sides.
- Easy change of tape.
- Compact design.
- Easy and economical maintenance.
- Extensive accessory programme, e.g. braked castors, packaging tables, and conveyors.



Item no.	
Model	Item no.
T-2002 5-5-9	482228313
T-2002 5-8-9	482228513

All measurements are in mm. Subject to alteration.

Specifications	T-2002 5-5-9	T-2002 5-8-9
Case dimensions*		
Max. (LxWxH) mm	∞ x 500 x 500	∞ x 500 x 800
Min. (LxWxH) mm	140 x 160 x 170	140 x 160 x 170
Tape overlap		
70 mm	●	●
50 mm	○	○
Tape width		
25 - 30 mm	○	○
38 - 50 mm	●	●
50 - 75 mm	○	○
Weight kg	165	168
Capacity*	Max. 30/ min.	
Electric specifications	3 x 230/400 V, 50-60 Hz, or 3 x 415/460 V, 50-60 Hz. Connected load 0.3 kW. Other specifications available upon request.	
Tape diameter	Max. 385 mm.	

● Standard ○ Optional* Depending on the construction and quality of the case. Subject to alteration.

Case sealers for uniform case sizes

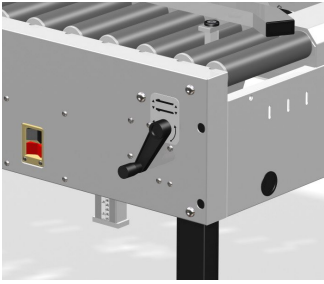

Crank handle adjustment for case size.

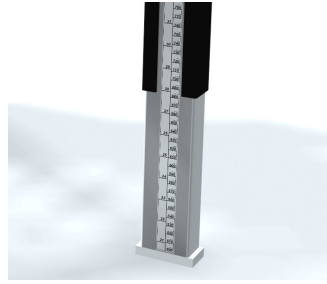

Tape measure on the legs of the machine for easy and precise working height adjustment.

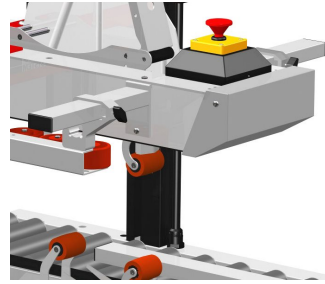

Side pressure guides and centrally placed emergency stop switch.

Accessories

- ▶ Tape dispensers - Standard
- ▶ Spare parts kit for dispensers
- ▶ Braked castors

Case sealers for uniform case sizes

T-4000/-4200 with automatic flap folding - top and bottom sealing

Infeed control with SOCO SYSTEM controller ensures efficient separation and high capacity.

Basic models

The compact machine is available in two basic models T-4000 and T-4200.

- The machine is very easy to adjust for current case size and adjustment can be carried out from both sides.
- Easy change of tape.
- Compact design.
- Easy and economical maintenance.
- Extensive accessory programme, e.g. braked castors, packaging tables, and conveyors.



Item no.	
Model	Item no.
T-4000 5-5-9	482408313
T-4000 5-8-9	482408513
T-4200 5-5-9	482428313
T-4200 5-8-9	482428513
T-4200 Maxi 5-8-9	482423973

All measurements are in mm. Subject to alteration.

Specifications	T-4000 5-5-9	T-4000 5-8-9	T-4200 5-5-9	T-4200 5-8-9	T-4200 Maxi 7-8-9
Case dimensions*					
Max. (LxWxH) mm	550 x 460 x 470	550 x 460 x 770	750 x 460 x 470	750 x 460 x 770	750 x 710 x 770
Min. (LxWxH) mm	200 x 120 x 100	200 x 120 x 100	200 x 120 x 100	200 x 120 x 100	200 x 170 x 100
Tape overlap					
70 mm	●	●	●	●	●
50 mm	○	○	○	○	○
Tape width					
25 - 30 mm	○	○	○	○	○
38 - 50 mm	●	●	●	●	○
50 - 75 mm	○	○	○	○	●
Side drives					
Height 50 mm	●	●	●	●	○
Height 80 mm	○	○	○	○	●
Weight kg	165	168	170	173	175
Capacity*	Max. 18/min.				
Electric specifications	3 x 230/400 V, 50-60 Hz, or 3 x 415/460 V, 50-60 Hz. Connected load 0.3 kW. Other specifications available upon request.				
Air consumption	Max. 0.6 l at 6 bar per case.				
Tape diameter	Max. 385 mm.				

● Standard ○ Optional* Depending on the construction and quality of the case. Subject to alteration.

Case sealers for uniform case sizes



Crank handle adjustment for case size.



Tape measure on the legs of the machine for easy and precise working height adjustment.



Automatic flap folding.

Accessories

- ▶ Tape dispensers - Standard
- ▶ Spare parts kit for dispensers
- ▶ Braked castors

Case sealers for uniform case sizes

HM-4200 With automatic flap folding – top sealing with hotmelt

Inlet control with SOCO SYSTEM controller ensures efficient carton separation and high capacity.

Basic models

The compact machine is available in two sizes.

- The machine is very easy to adjust for different carton sizes and adjustment can be carried out from both sides.
- Compact design.
- Easy to maintain and low maintenance costs.
- Wide range of accessory equipment, e.g. braked castors, packaging tables, and conveyors.

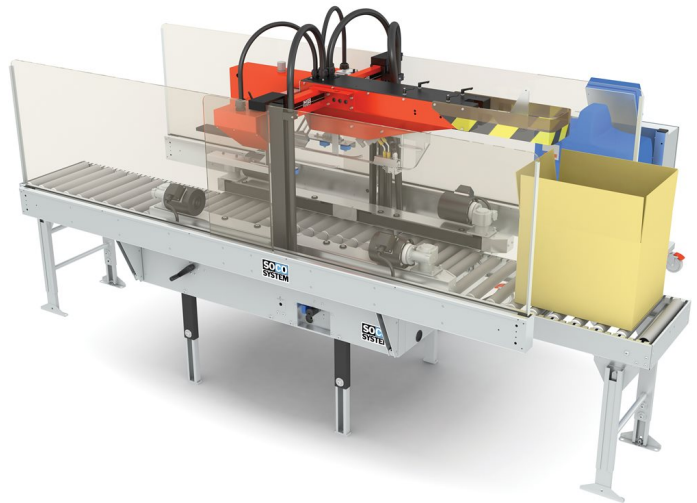

Item no.

Model	Item no.
HM-4200 5-5-9	487658305
HM-4200 5-8-9	487658505

All measurements are in mm. Subject to alteration.

Specifications	HM-4200 5-5-9	HM-4200 5-8-9
Case dimensions*		
Max. (LxWxH) mm	500 x 460 x 470	500 x 460 x 770
Min. (LxWxH) mm	200 x 100 x 100	200 x 100 x 100
Side drives		
Height 50 mm	●	●
Height 80 mm	○	○
Capacity*	Max. 9/min.	
Electric specifications	3 x 230/400 V, 50-60 Hz, or 3 x 415/460 V, 50-60 Hz. Connected load 0.3 kW. Other specifications available upon request.	
Air consumption	Max. 2.5 l at 6 bar per case.	

● Standard ○ Optional* Depending on the construction and quality of the case. Subject to alteration.

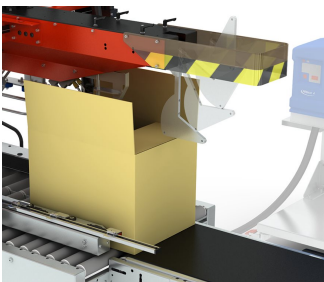

Folding of inside and outside flaps is very efficient and most carton qualities can be handled.

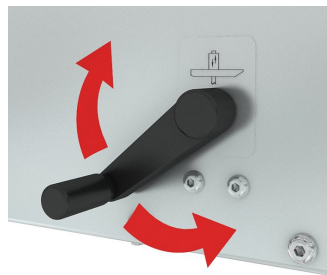

The machine is easy to adjust for different carton sizes.

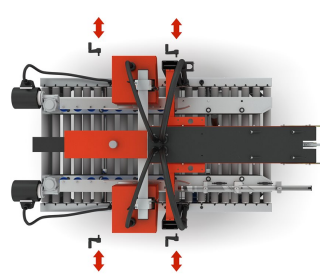

The machine can be adjusted from both sides.



Hotmelt equipment from several different manufacturers (e.g. Nordson or Robatech) can be used.

Case sealers for random case sizes

T-55 Automatic adjustment for case size - Top and bottom closure

The automatic height and width adjustment makes the T-55 ideal in packing lines where case sizes vary, e.g. in the dispatch department of warehouses. Two operators can work simultaneously on either side of the packing table.

The T-55 can operate as a fully automatic top and bottom sealer provided the top flaps of the case are closed by means of a control label or a small piece of tape.

Basic models

T-55 and T-55 Maxi. Both models are available with high pillars for extra tall cases.

- Easy tape and dispenser replacement.
- Easy to maintain with low maintenance and spare parts costs.
- Wide range of accessory equipment.

Electro-galvanised or stainless steel finish.



Item no.

Model	Item no.
T-55 5-5-7	437756713
T-55 5-8-7	437756913
T-55 Maxi 7-5-7	437752133
T-55 Maxi 7-8-7	437752333

All measurements are in mm. Subject to alteration.

Case sealers for random case sizes

Specifications	T-55 5-5-7	T-55 5-8-7	T-55 Maxi 7-5-7	T-55 Maxi 7-8-7
Case dimensions*				
Max. (LxWxH) mm	∞ x 510 x 510	∞ x 510 x 810	∞ x 720 x 510	∞ x 720 x 810
Min. (LxWxH) mm	160 x 95 x 85	160 x 95 x 220	160 x 150 x 115	160 x 150 x 220
Tape overlap				
70 mm	●	●	●	●
50 mm	○	○	○	○
Tape width				
25 - 30 mm	○	○	○	○
38 - 50 mm	●	●	○	○
50 - 75 mm	○	○	●	●
Side drives				
Height 50 mm	●	●	○	○
Height 80 mm	○	○	●	●
Working height max./min.				
920 - 820 mm	○	○	○	○
820 - 720 mm	○	○	○	○
720 - 620 mm	●	●	●	●
620 - 520 mm	○	○	○	○
520 - 420 mm	○	○	●	○
Weight kg	175	165	170	170
Capacity*	Max. 16 cases/ min.			
Electric specifications	3 x 230/400 V, 50-60 Hz, or 3 x 415/460 V, 50-60 Hz. Connected load 0.3 kW. Other specifications available upon request.			
Air consumption	Max. 8.5 l at 6 bar per case.			
Tape diameter	Max. 385 mm.			
● Standard ○ Optional*Depending on the construction and quality of the case. Subject to alteration.				

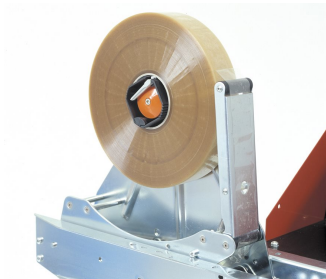

High quality tape dispensers.

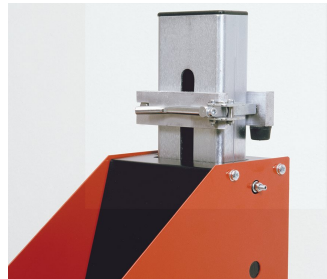

Pillar stop for maximum efficiency.

Case sealers for random case sizes



Accessories

- ▶ Tape dispensers - Standard
- ▶ Spare parts kit for dispensers
- ▶ Braked castors

The model T-55 is for packing stations that handle many different sizes of case.

Machine dimensions

T-55 5-5-7 / 5-8-7

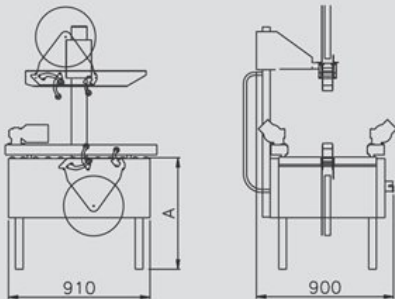

T-55 Maxi 7-5-7 / 7-8-7

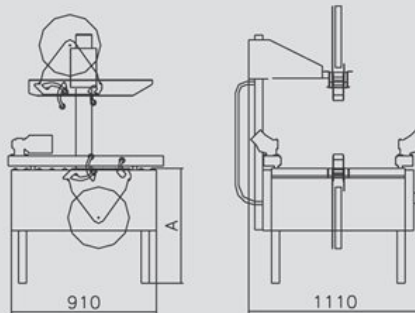

Alle measures are in mm. A = working height. Subject to alteration.

Case sealers for random case sizes

T-602 Fully automatic - Top and bottom closure

Automatic case size adjustment and flap closure. Together with SOCO SYSTEM controllers, complete feed-in control and maximum capacity is achieved.

Basic models

T-602 and T-602 Maxi. An extensive programme of accessories is available for both models, e.g. extra high pillars.

Smallest external dimensions on the market

The T-602 is a very compact machine with the smallest external dimensions in relation to its high capacity.

- Wide range of accessory equipment.
- Easy tape and dispenser replacement.
- Easy to maintain with low maintenance and spare parts costs.

Electro-galvanised finish.

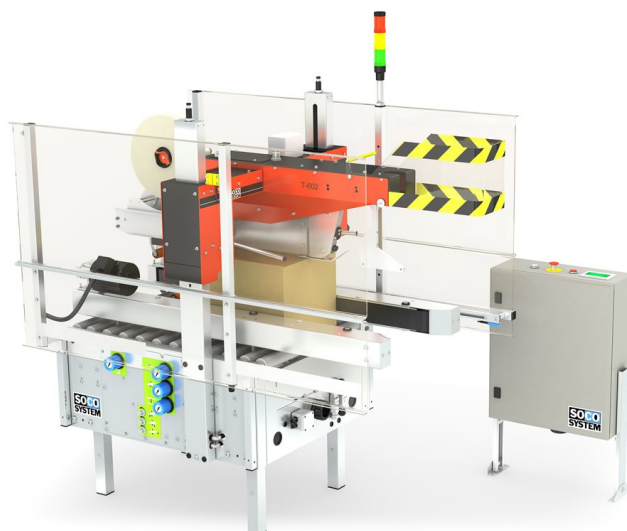

Item no.	
Model	Item no.
T-602 5-5-8	460502513
T-602 5-8-8	460502713
All measurements are in mm. Subject to alteration	

Specifications	T-602 5-5-8	T-602 5-8-8
Case dimensions*		
Max. (LxWxH) mm	600 x 460 x 475	600 x 460 x 765
Min. (LxWxH) mm	200 x 120 x 120	200 x 120 x 220
Tape overlap		
70 mm	●	●
50 mm	○	○
Tape width		
25 - 30 mm	○	○
38 - 50 mm	●	●
Side drives		
Height 50 mm	○	○
Height 80 mm	●	●
Working height max./min.		
920 - 820 mm	○	○
820 - 720 mm	●	●
720 - 620 mm	○	○
620 - 520 mm	○	○
520 - 420 mm	○	○
Weight kg	220	220
Capacity*	Max. 8 cases/min.	
Electric specifications	3 x 230/400 V, 50-60 Hz, or 3 x 415/460 V 50-60 Hz. Connected load 0.3 kW. Other specifications available upon request.	
Air consumption	5-5-8 max. 16.7 l at 6 bar per case, 5-8-8 max. 21.5 l at 6 bar per case.	
Tape diameter	Max. 385 mm.	
● Standard ○ Optional* Depending on the construction and quality of the case. Subject to alteration.		

Case sealers for random case sizes

Accessories

- ▶ Tape alarm
- ▶ Side pressure guide for T-55 and T-602
- ▶ Tape dispensers - Standard
- ▶ Spare parts kit for dispensers

T-55 Bottom closure - Automatic adjustment for case size

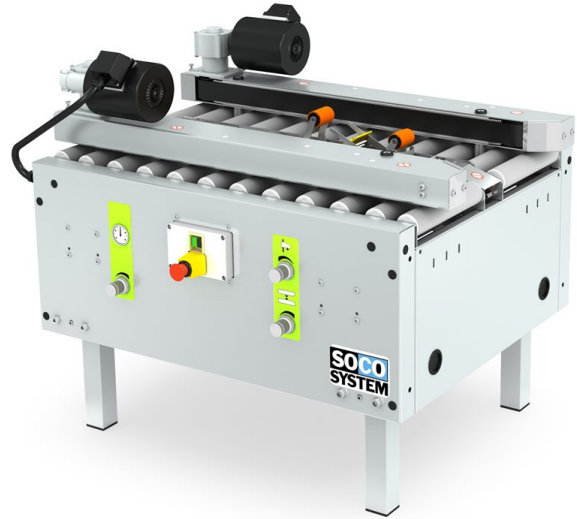

Flap closers for uniform case sizes

FT-10/-12

Manual height and width adjustment.

The FT-10 is designed for automatic flap closure in automatic production lines, handling batches of uniform cases.

For particularly long cases with up to 150 mm extra length, the FT-12 is the solution (see table).

Both machines adapt easily to existing case sealers without automatic flap closing arrangement, but are ideal also for installation before a strapping machine.



Item no.

Model	Item no.
FT-10 5-5-7	439326703
FT-12 5-5-7	439336703
FT-12 5-8-7	439336903
FT-12 Maxi 7-8-7	439332303

All measurements are in mm. Subject to alteration.

Specifications	FT-10 5-5-7	FT-12 5-5-7	FT-12 5-8-7	FT-12 Maxi 7-8-7
Case dimensions*				
Max. (LxWxH) mm	700 x 460 x 470	850 x 460 x 470	850 x 460 x 770	850 x 710 x 625
Min. (LxWxH) mm	200 x 120 x 95	300 x 120 x 95	300 x 120 x 95	300 x 120 x 125
Side drives				
Height 50 mm	●	●	●	○
Height 80 mm	○	○	○	●
Working height max./min.				
920 - 820 mm	○	○	○	○
820 - 720 mm	○	○	○	○
720 - 620 mm	●	●	●	●
620 - 520 mm	○	○	○	○
520 - 420 mm	○	○	○	○
Weight kg	175	175	175	220
Capacity*	Max. 18 cases/ min.			
Electric specifications	3 x 230/400 V, 50-60 Hz, or 3 x 415/460 V, 50-60 Hz. Connected load 0.3 kW. Other specifications available upon request.			
Air consumption	FT-10/-12 0.6 l at 6 bar per case.			
● Standard ○ Optional* Depending on the construction and quality of the case. Subject to alteration.				

Flap closers for random case sizes

FT-55

Automatic height and width adjustment.

The FT-55 is designed for automatic flap closure in automatic production lines where several lines conveying random-sized cases converge into one.

The machine adapts easily to existing case sealers without automatic flap closing arrangement, but is ideal also for installation before a strapping machine, etc.

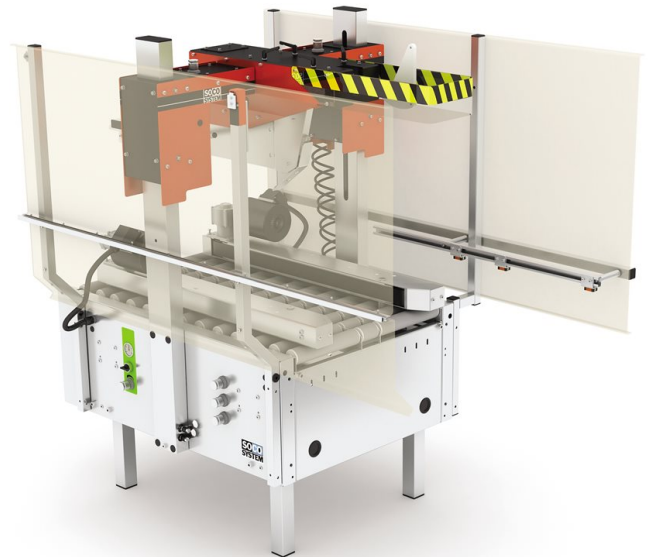

Item no.

Model	Item no.
FT-55 5-5-7	461166703
FT-55 Maxi 7-8-7	461202303

All measurements are in mm. Subject to alteration

Specifications	FT-55 5-5-7	FT-57 Maxi 7-8-7
Case dimensions*		
Max. (LxWxH) mm	600 x 460 x 470	850 x 710 x 640
Min. (LxWxH) mm	200 x 120 x 95	300 x 150 x 120
Side drives		
Height 50 mm	●	○
Height 80 mm	○	●
Working height max./min.		
920 - 820 mm	○	○
820 - 720 mm	○	○
720 - 620 mm	●	●
620 - 520 mm	○	○
520 - 420 mm	○	○
Weight kg	230	230
Capacity*	Max. 8 cases/ min.	
Electric specifications	3 x 230/400 V, 50-60 Hz, or 3 x 415/460 V, 50-60 Hz. Connected load 0.3 kW. Other specifications available upon request.	
Air consumption	FT-55 5-5-7 Max. 16,7 - 19,2 l at 6 bar per case. FT-55 7-8-7 Max. 22.2 l at 6 bar per case.	
● Standard ○ Optional* Depending on the construction and quality of the case. Subject to alteration.		

Tape dispensers - Standard

For case sealers operated from the right.

Many years of experience have resulted in a superb tool. With the right tape, the dispenser is noiseless, and replacement of tape is easy and quickly done.

The SOCO SYSTEM dispenser is available in three different widths:

- 30 mm wide dispenser for tape widths ranging from 25 to -30 mm. Tape overlap is 50 mm.

- 50 mm wide tape dispenser for tape widths ranging from 38 to -50 mm. The tape overlap is 50 or 70 mm.

- 75 mm wide dispenser for tape widths ranging from 50 to -75 mm. The tape overlap is 50 or 70 mm.

- The hub brake can be adjusted for various tape sizes.
- The tape roller hub can be adjusted for the exact tape width.
- Double rear rollers are a special feature of the SOCO SYSTEM dispensers.



Item no.				
Type	Tape overlap	Tape width	Top dispenser/ Item no.	Bottom dispenser/ Item no.
50.30	50	30	425003721	425003711
25.30	25	30	425003921	425003911
25.50	25	50	425003821	425003811
50.50	50	50	425003321	425003311
70.50	70	50	425003121	425003111
50.75	50	75	425003421	425003411
70.75	70	75	425003521	425003511
50.100	50	100	425002021	425002011
70.100	70	100	425002221	425002211
50.50/30	50	30	425003621	425003611

All measurements are in mm. Subject to alteration.

Accessories

- ▶ Spare parts kit for dispensers
- ▶ Tape alarm

Tape dispensers - Opposite hands

For case sealers operated from the left.

Many years of experience have resulted in a superb tool. With the right tape, the dispenser is noiseless, and replacement of tape is easy and quickly done.

The SOCO SYSTEM dispenser is available in three different widths:

- 30 mm wide dispenser for tape widths ranging from 25 to -30 mm. Tape overlap is 50 mm.
- 50 mm wide tape dispenser for tape widths ranging from 38 to -50 mm. The tape overlap is 50 or 70 mm.
- 75 mm wide dispenser for tape widths ranging from 50 to -75 mm. The tape overlap is 50 or 70 mm.

- The hub brake can be adjusted for various tape sizes.
- The tape roller hub can be adjusted for the exact tape width.
- Double rear rollers are a special feature of the SOCO SYSTEM dispensers.



Item no.				
Type	Tape overlap	Tape width	Top dispenser Item no.	Bottom dispenser Item no.
50.30	50	30	425003722	425003712
25.30	25	30	425003922	425003912
25.50	25	50	425003822	425003812
50.50	50	50	425003322	425003312
70.50	70	50	425003122	425003112
50.75	50	75	425003422	425003412
70.75	70	75	425003522	425003512
50.100	50	100	425002022	425002012
70.100	70	100	425002222	425002212
50.50/30	50	30	425003622	425003612

All measurements are in mm. Subject to alteration.

Accessories

- ▶ Spare parts kit for dispensers
- ▶ Tape alarm

Spare parts kit for dispensers

The tape dispenser is the heart of a case sealer.

It is important that it has optimum performance at all times. The spare parts kit contains the most vital wear-and-tear parts so as to avoid long production down-time, all housed in a user-friendly, easy-to-store, hard-wearing container.

It is easy to re-order and keep updated - an order form is included with the kit.



Item no.

Dispenser type	Item no.
70.50/ 50.50	463000100
70.75	463000500
70.100	463000800

Subject to alteration.

Tape alarm

All dispensers can be fitted with a monitoring system to supervise the sealing process.

The monitoring system supervises the tape teller and the knife by means of photocells. The alarm generates an audio visual warning and, if required, it can stop the machine at the same time.

Alarm is given in the following cases:

- No tape is applied.
- Tape breaks during sealing.
- Tape not cut and case continues to pull tape from the dispenser.
- Tape roller empty.



3-flap folder for T-10 and T-100

The 3-flap folder facilitates the feed-in of cases. The operator pushes the case into the machine while folding its rear flap. The front and side flaps are folded by the 3-flap folder. Adjustable for any case size.

Item no.

Item no.

481980001

Subject to alteration.

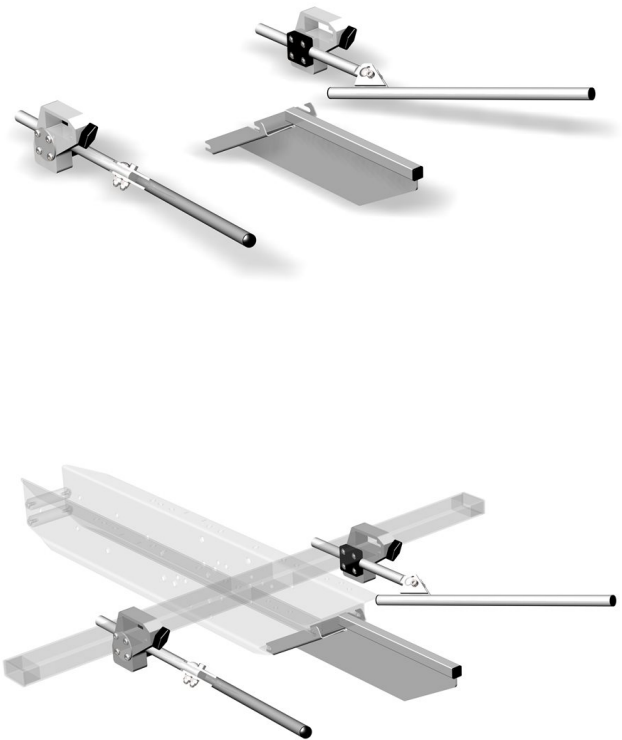

Easy-open Zipper system

A small piece of paper with a big effect.

The Zipper is applied on the adhesive side of the tape during case sealing. It keeps a triangular area free of glue and is easy to lift with one finger.

No need for scissors, knives or the like, and, therefore, no risk of damaging the contents.

The Zipper system can be used for most SOCO SYSTEM case sealers.

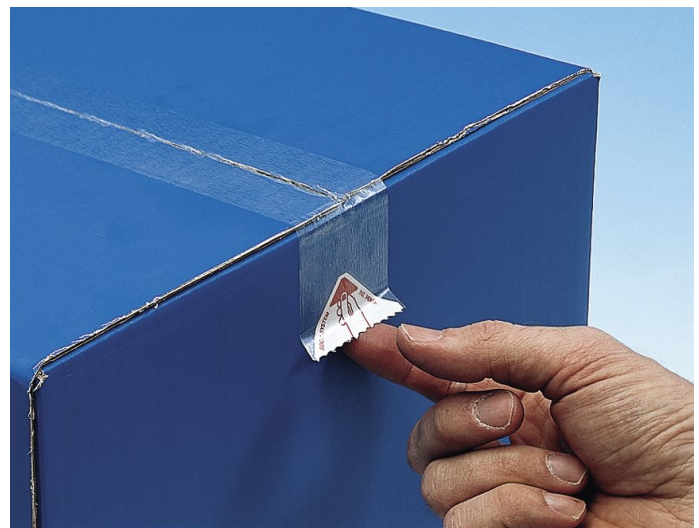

Side pressure guide for T-55 and T-602

The side pressure guide ensures that the case is held firm during the sealing process.

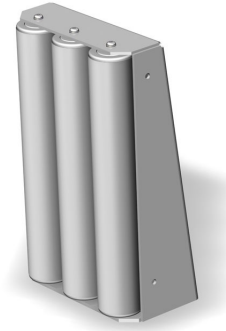

Top drive

A motor-driven top assembly ensures stability during the sealing process of particularly tall or heavy cases.

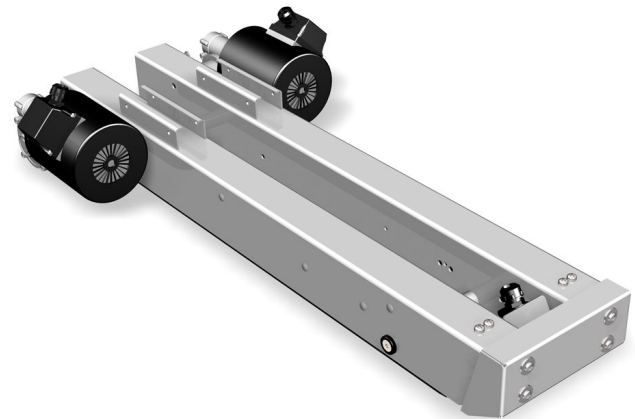

Safety switch

The safety switch is located at the inlet end of the top drive. On activation, the machine will stop.

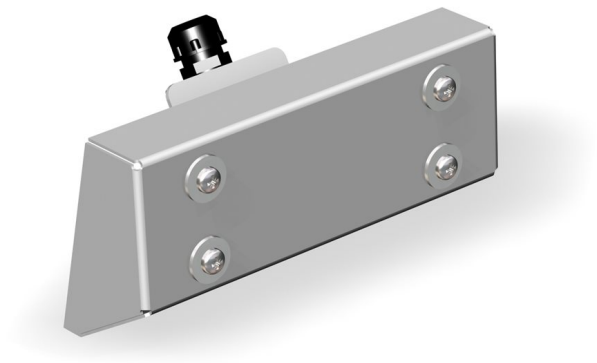

Narrow side-drives

All standard machines are fitted with 50 mm high side-drives. Available with 80 mm high side-drives at a surcharge.

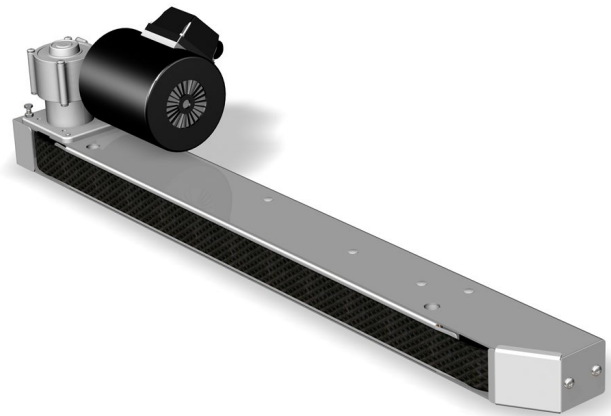

Wide side-drives

All Maxi machines are fitted with 80 mm high side-drives. Available with 50 mm high side-drives at a surcharge.

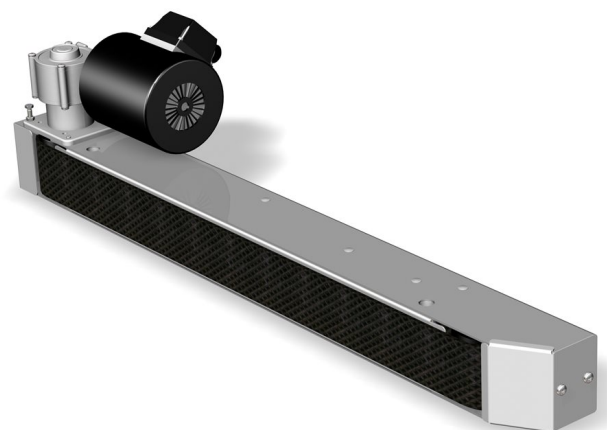

Extended side-drives

200 mm or 400 mm at in- and outlet.
The strong side-drives are prepared for coders, labelling machinery, etc.

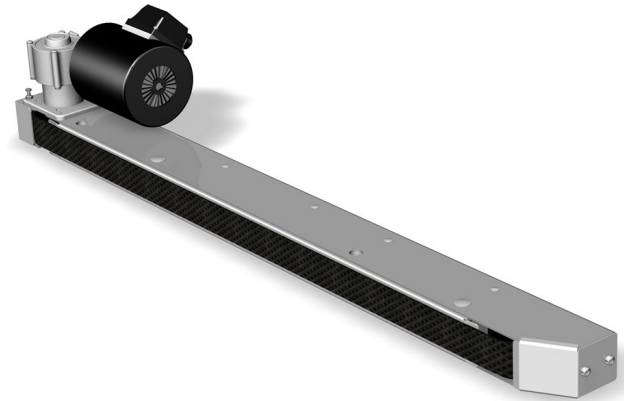

Raised side-drives

The side-drives can be raised 50/100/150/200 mm above the roller table.

Used particularly for high, short cases.

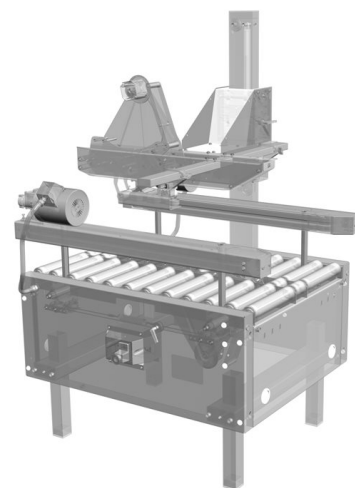

Safety cover

The safety cover prevents accidents during operation. If the cover is opened, the machine stops.

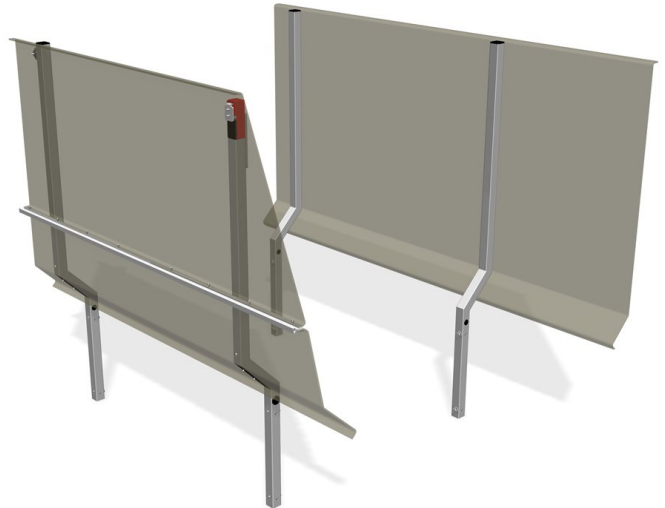

Fixed pillar stop

The pillar stop "locks" the top assembly of the machine according to a chosen maximum case height.

Specially suited for machines with automatic adjustment for case size such as the T-55.

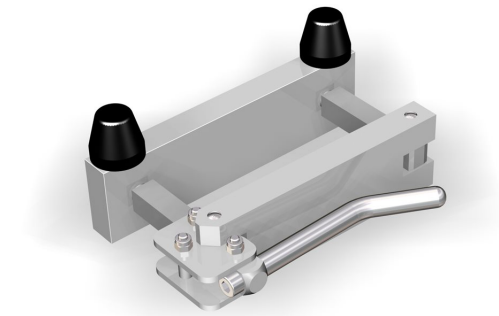

Resilient stop

To achieve spring suspension of the top assembly of the machine models T-10, T-100 and T-100 Mini, a resilient stop can be fitted.

Suitable where the cases are slightly overfilled, and the top assembly needs to rebound.

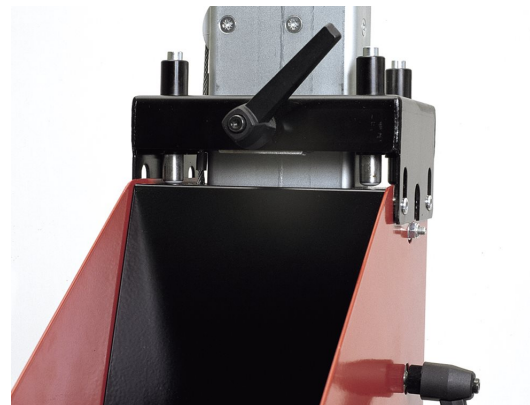

Inline system

Offers an efficient and ergonomically correct working station on few square metres when combined with SOCO SYSTEM case sealers.

The inline system is used as packing table in front of the case sealer and as outlet and accumulation line after the machine.

The system consists of a 1 m roller conveyor with case holder in front of the machine and a 1 or 2 m roller conveyor with end stop after the machine.

The roller conveyors are available in standard widths with plastic rollers.

The system is delivered complete with supports and coupling fittings for connection to case sealer.

- The inline system is silent with minimum friction.

The inline system can be fitted with castors.



Specifications

Conveying	
Tubes	Ø 48 mm impact-proof plastic.
Axles	Ø 8 mm aluminium.
End bearings	Plastic insert with stainless steel balls.
Frames	Electro-galvanised steel.
Axle pitch	As standard, the inline system is delivered with a 90 mm pitch. Please contact our sales department if a different pitch is required.
Width	200, 300, 400, 500, 600 mm.
Load	10 kg per roller. Max. 75 kg per metre conveyor.

Subject to alteration.

Item no.

Width	For standard machines (type 5-) 1+1m/ Item no.	For standard machines (type 5-) 1+2m/ Item no.	For wide machines (type 7-) 1+1m / Item no.	For wide machines (type 7-) 1+2m / Item no.
200	450207201	450207202	450207203	450207204
300	450207301	450207302	450207303	450207304
400	450207401	450207402	450207403	450207404
500	450207501	450207502	450207503	450207504
600	450207601	450207602	450207603	450207604

All measurements are in mm. Subject to alteration.

Accessories

- ▶ Braked castors

Boomerang system

The boomerang system is ideal as a "one-man packing station" where a single operator can fill, seal, and palletise cases from practically the same position.

The boomerang packing station allows three operations to be carried out within a very limited area, approx. 8 m²:

1. **Case erecting** and holding the empty case in place. The operator has both hands free for filling.
2. **Case sealing** at the top and bottom, the cases then pass onto the conveyor and accumulate directly behind the operator.
3. **The cases are palletised** when the accumulating conveyor is full.

Delivered complete with supports and coupling fittings.

The entire system can be fitted with castors.



Item no.	
Width	Item no.
300	450180303
400	450180403
500	450180503

All measurements are in mm. Subject to alteration.

Specifications

Conveying	
Tubes	Ø 48 mm impact-proof plastic.
Axles	Ø 8 mm aluminium.
End bearings	Plastic insert with stainless steel balls.
Frames	Electro-galvanised steel.
Axle pitch	As standard, the boomerang system is delivered with a 90 mm pitch. Please contact our sales department if a different pitch is required.
Width	300, 400, 500 mm.
Load	10 kg per roller. Max. 75 kg per metre conveyor.

Subject to alteration.

Accessories

- ▶ Braked castors

3		
3-flap folder for T-10 and T-100	28	
B		
Boomerang system	34	
E		
Easy-open Zipper system	28	
Extended side-drives	31	
F		
Fixed pillar stop	32	
FT-10/-12	23	
FT-55	24	
H		
HM-4200 With automatic flap folding – top sealing with hotmelt	17	
I		
Inline system	33	
N		
Narrow side-drives	30	
R		
Raised side-drives	31	
Resilient stop	32	
S		
Safety cover	32	
Safety switch	30	
Side pressure guide for T-55 and T-602	29	
Spare parts kit for dispensers	27	
ST-10 For side taping- Top- or bottom closure	7	
T		
T-10 for round-the-clock applications - Top- and bottom closure	3	
T-100 Mini Mini For the very small cartons - Top and bottom closure	1	
T-100 motorized hand dispenser - Top and bottom closure	2	
T-2000 top and bottom sealing	11	
T-2002 with top and bottom drive - top and bottom sealing	13	
T-400 Case sealer with automatic flap closure - Top and bottom closure	5	
T-4000/-4200 with automatic flap folding - top and bottom sealing	15	
T-55 Automatic adjustment for case size - Top and bottom closure	18	
T-55 Bottom closure - Automatic adjustment for case size	22	
T-602 Fully automatic - Top and bottom closure	21	
		Tape alarm 27
		Tape dispensers - Opposite hands 26
		Tape dispensers - Standard 25
		Top drive 29
		TT-10 For flat items - Top closure 9
		W
		Wide side-drives 30



The SOCO SYSTEM

From case erecting to pallet securing

The SOCO SYSTEM product range handles cases, plastic crates, trays, pallets, and many of your products.

The SOCO SYSTEM product range is designed to increase efficiency and eliminate physically strenuous work functions.

One system – one supplier

There are many advantages of full product compatibility; less paperwork and no time wasted in adapting products from different suppliers.

Meet your future requirements

Add modules and functionality, relocate modules, or whatever fits your future needs.

Call us, mail us, or visit us at www.socosystem.com

Your local SOCO SYSTEM dealer:

COPYRIGHT SOCO SYSTEM 2014



Head office:
SOCO SYSTEM A/S
 Helgeshoej Allé 16D
 DK-2630 Taastrup
 Denmark
 Tel +45 43 52 55 66
 Fax +45 43 52 81 16
 info@socosystem.com
 www.socosystem.com



Flextronics, Netherlands



Sig. Ágústsson, Iceland



Laru, Germany



Toms, Denmark



Rioja, Spain



Bouché Père & Fils, France



United Milk, England



Altmark Käserei, Germany