



Function

Flexible link between the motor and the machine which transmits high power.
High quality belts which can be used in hard conditions atmosphere and each time the security factor is important (mines, petroleum industries).

Conception

Endless V belts are made of :

- polychloroprene rubbers which guarantee a constant hardness
- polyester cord with controlled elasticity and high capacity of traction
- single wrapping (for SPZ sections) and double wrapping (for SPA, SPB and SPC sections) impregnated with polychloroprene compound which resists heat, oil, abrasion and ozone aggressions.

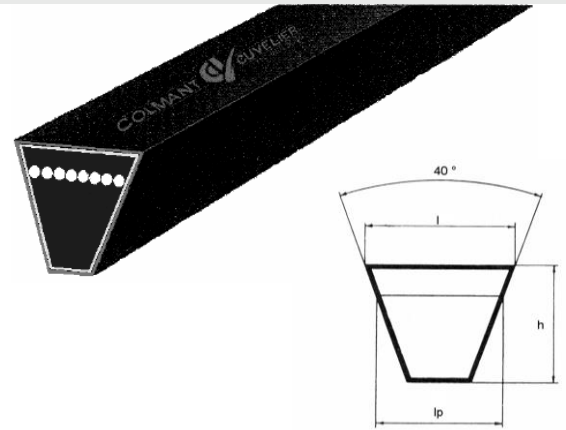

General Specifications

- working temperature : -35° to + 100°C ; + 120°C in peak
- antistatic following standard NF T 47 104 / ISO1813
- V belt sections following standard E 24 - 213
- resistant to oil projection, hydrocarbure and diluted acids ISO1817
- quality "ignifuge" : fire resistance according to standard S4 (sept. 86) French mines
- endure centrifugal strength
- good draining of heat at high speed
- reduce bulkiness of transmission :
 - smaller and lighter pulleys
 - smaller protection carter
 - higher speed solutions

SECTION	l	h	lp
SPZ	9.7	8	8,5
SPA	12.7	10	11
SPB	16.3	13	14
SPC	22	18	19

Stabilisation Process "ST"

The stabilization process "ST" guarantees a small and continuous margin on the length. The length of V. belts follows the standard NF ISO 4184.

It means:

- easy to install
- even distribution of loads on multiple belt drives
- eliminate vibrations

Marking

6 C MADE IN EU **VECO 200 5000 SPC DYNAM LONGUE DUREE** ATEX COMPLIANT **ST**
COLMANT CUVELIER

On our DYNAM belts, you can read:

- the production date (codes for month and year) : 6C
- ST mark
- the pitch length measured under strength, as well as the section: 5000 SPC
- quality "IGNIFUGE LONGUE DUREE" in red

THE "LABEL DYNAM"

Design

The DYNAM® system allows us to supply a pre-tensionned belt. This system ensures the correct tension by the mere reading of the length between 2 marks. This measure only requires to be done once when tensening the belt. There is no need to check the tension twice. (see data sheet n°10003).

Performance

- The 1 % slip guarantees a performance of 95 %.
- Improved transmitted power by 20 %.
- Optimum performance is obtained when the linear speed is between 30 m/s and 33 m/s.
- The power transmitted is the same as the Veco 200 Label Dynam range



Pitch lengths of our V belts (in mm)

The sections of V belts VECO 200® with "label DYNAM" that we can supply are : SPZ, SPA, SPB, SPC. Only the sizes in yellow are available with the DYNAM System.

SPZ (10 x 8)				SPA (13 x 11)				SPB (16 x 14)			SPC (22 x 18)		
630	1000	1600	2800	800	1250	1600	2800	1250	2240	4500	2000	4000	8000
710	1120	1800	3150	900	1400	1800	3150	1400	2500	5000	2240	4500	9000
800	1250	2000	3550	1000		2000	3550	1600	2800	6300	2500	5000	10000
900	1400	2240		1120		2240	4000	1800	3150	7100	2800	5600	11200
		2500				2500	4500	2000	3550	8000	3150	6300	12500
									4000		3550	7100	
Lp = li + 38 Lp = le - 13				Lp = li + 45 Lp = le - 18				Lp = li + 60 Lp = le - 22			Lp = li + 83 Lp = le - 30		
Weight / metre 0,078 kg				Weight / metre 0,139 kg				Weight / metre 0,228 kg			Weight / metre 0,425kg		

Lp : pitch length; li : internal length ; le : external length

Stocking conditions

Belts must be stocked under the following conditions :

- the room must be dry, without dust and well ventilated.
- temperature must be between +5°C and +25°C.
- no condensation, maximum humidity of air : 65 %.
- avoid direct sun light and high artificial light due to ultraviolet.
- avoid contact with chemical products, solvent, petrol, lubricant, acid, volatile components, greases.
- no material which can produce ozone, like high tension electric material, electric motors or other materials which can produce sparks or electric discharges.
- the stocked belts must not have been stressed, compressed or deformed.
- set them more than 1 meter from radiators or heat source.
- avoid direct contact with some kinds of metal (copper, manganese, ...)
- avoid contact with sharp, abrasive and angular surfaces.
- the material of boxes, packings and the coverings must not contain nocive substances for the belts like copper or creosotes.

Stock turn : The best thing to do is : "first in, first out"

Cleaning : Cleaning with water and soap is harmless. You must never use organic solvents like trichlorethylene, carbone tetrachlorure or ether of petrol, no abrasive nor sharp tools. The cleaned belts must be dried at ambient temperature.